



# MODEL TFXL

## ULTRASONIC FLOW METER

Installation and Operating Instructions





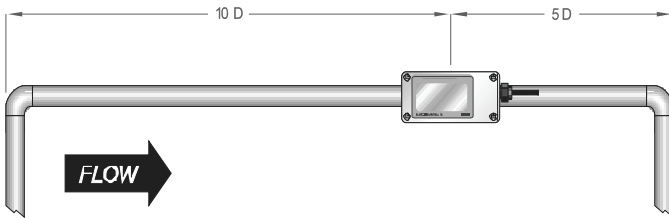
# TABLE OF CONTENTS

|                                 |    |
|---------------------------------|----|
| • Quick Start Instructions      | 4  |
| • Introduction                  | 6  |
| • Specifications                | 7  |
| • Symbol Explanations           | 7  |
| • Components and Terminology    | 8  |
| • Flow Meter Mounting Procedure | 11 |
| • Electronic Connections        | 14 |
| • 4-20mA Output Connections     | 16 |
| • Pulse Output Connections      | 18 |
| • Applying Power                | 20 |
| • Software Utility              | 22 |
| • Maintenance                   | 37 |
| • Troubleshooting Guide         | 38 |
| • Warranty                      | 39 |
| • Service Instructions          | 40 |
| • Drawings                      | 41 |
| • Notes                         | 42 |

# QUICK-START INSTRUCTIONS

This manual contains detailed operating instructions for the TFXL instrument. The following condensed instructions are provided to assist an experienced operator in basic operation of the instrument. If the operator is unfamiliar with this type of instrument, refer to the detailed explanations located on pages 10-32.

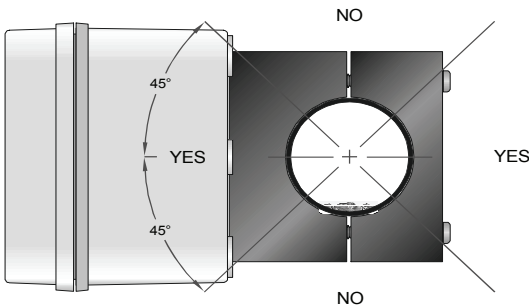
- A. Select a flow meter mounting location with at least 10 pipe diameters upstream and 5 diameters downstream from the meter with no flow disturbances (i.e. elbows, tees, needle valves, etc.). See **Figure 1**.



FLOW METER MOUNTING

**Figure 1**

- B. On horizontal pipe, choose a flow meter mounting location within approximately 45-degrees of the side of the pipe. See **Figure 2**. Locate the flow meter so that the pipe will be completely full of liquid when flow is occurring in the pipe. Avoid mounting on vertical pipes where the flow is moving in a downward direction.



**Figure 2**

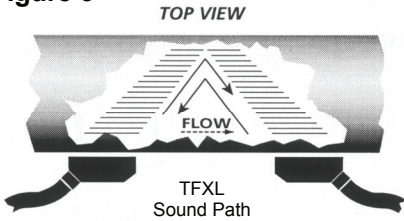
FLOW METER MOUNTING ORIENTATION

- C. Remove rust, scale and paint from the flow meter mounting location. Clean to bare metal. Plastic pipes do not require preparation.
- D. Apply a thin, even layer of silicone grease to the two transducer faces. Ensure that air bubbles are not present over the two brown plastic sound-guides. Place the electronic portion of the flow meter onto the prepared area of pipe, making sure that the flow direction arrow is pointing in the direction of flow. Place the clamp portion opposite the flow meter and secure with the enclosed screws. Only moderate torque is required on the screws—DO NOT OVER TIGHTEN and DO NOT ROTATE the flow meter on the pipe once the screws have been tightened.
- E. Connect 11-30 Vdc to the power terminals within the TFXL transmitter. Ensure that the power supply is capable of sourcing a minimum of 0.25 Amps. Observe polarity.
- F. Connect either the 4-20mA, pulse output or both outputs to the data acquisition or monitoring system as required.
- G. Apply power.
- H. If the pipe is full of liquid, a flow rate reading will appear. If the pipe is empty or partially empty, a ERROR 0010 will be shown on the display. The error will clear when flow resumes and the pipe fills up with water.
- I. Configuration changes and advanced troubleshooting can be accomplished using the UltraLink software utility, a PC computer and a PC interface cable.

# INTRODUCTION AND OPERATING THEORY

TFXL transit time flow meters measure flow velocity by sending pulses of ultrasound energy back and forth between two piezoelectric devices. See **Figure 3**. The piezoelectric components are located behind the oval-shaped, dark plastic sound guides that are embedded in the flow sensor clamp. If the liquid inside of the pipe is moving, the sound will travel faster when it is sent in the

**Figure 3**



direction of liquid flow than it will when it is sent against the liquid flow. The TFXL microprocessor generates the pulses and measures the elapsed time required for the sound to travel between the piezoelectric devices. Liquid velocity is proportional to the difference in

time between upstream and downstream time measurements. The TFXL compensates for gas content in the liquid and will remove gaseous content from flow rate and totalizer readings. Outputs from the flow meter include 4-20 mA analog, turbine frequency output/pulse output.

## Model Number Matrix

**D T F X L**    **1**

### Display Options

- 1) ABS Enclosure-Blind (no display)
- 2) ABS Enclosure-Display (rate & total)
- 3) Polycarbonate Enclosure-Blind
- 4) Polycarbonate Enclosure-Display

### Pipe Size

- |                         |                             |
|-------------------------|-----------------------------|
| <b>A)</b> ½" ANSI Pipe  | <b>K)</b> 1½" Copper Pipe   |
| <b>B)</b> ¾" ANSI Pipe  | <b>L)</b> 2" Copper Pipe    |
| <b>C)</b> 1" ANSI Pipe  | <b>M)</b> ½" Tubing         |
| <b>D)</b> 1¼" ANSI Pipe | <b>N)</b> ¾" Tubing         |
| <b>E)</b> 1½" ANSI Pipe | <b>P)</b> 1" Tubing         |
| <b>F)</b> 2" ANSI Pipe  | <b>Q)</b> 1¼" Tubing        |
| <b>G)</b> ½" Copper     | <b>R)</b> 1½" Tubing        |
| <b>H)</b> ¾" Copper     | <b>S)</b> 2" Tubing         |
| <b>I)</b> 1" Copper     | <b>X)</b> Remote Transducer |
| <b>J)</b> 1¼" Copper    | (Not shown in this manual)  |

### Output Options

- 1) 4-20 mA and Pulse

### Connector Options

- N)** ½-inch Conduit Hole
- A)** Water-tight Cable Clamp
- C)** 4-Pin Connector (male)
- D)** 1/2 inch Flexible Conduit Connector

### Accessories

PC Cable w/Ultralink Software  
90-240VAC Power Supply

### Part Number

D010-0204-001  
D005-2502-005

## SPECIFICATIONS/OPERATING CONDITIONS

For a complete table of specifications, see Series TFXL Data Sheet

| Description                    | Specification  |
|--------------------------------|--|
| <b>Input Voltage</b>           | 11-30 VDC @ 0.25A  |
| <b>Flow Range Reference</b>    | 0.1 to 40 FPS [0.03 to 12.4 MPS]   |
| <b>Sch 40 ½" Pipe</b>          | 0.5 to 25 GPM [20 to 850 BPD]  |
| <b>Sch 40 ¾" Pipe</b>          | 1.0 to 55 GPM [40 to 1800 BPD]   |
| <b>Sch 40 1" Pipe</b>          | 2.0 to 100 GPM [80 to 3400 BPD]  |
| <b>Sch 40 1¼" Pipe</b>         | 4.0 to 150 GPM [170 to 5000 BPD]   |
| <b>Sch 40 1½" Pipe</b>         | 5.0 to 220 GPM [170 to 7500 BPD]   |
| <b>Sch 40 2" Pipe</b>          | 8.0 to 400 GPM [275 to 13500 BPD]  |
| <b>Accuracy</b>                | ±1% of rate above 1 FPS [0.3 MPS]  |
| <b>Environment</b>             | Indoor use   |
| <b>Ambient Temperature</b>     | General Purpose: 0 to +185°F [-20 to +85°C]<br>Hazardous Area: 0 to +105°F [-20 to +40°C]  |
| <b>Altitude</b>                | Up to 2000 meters  |
| <b>Humidity</b>                | -20° to 31°C; 80% max; decreasing linearly to 50% at 40°C  |
| <b>Transient Overvolt-ages</b> | According to installation category 1, in accordance with IEC 664   |
| <b>Pollution Degree</b>        | 2 in accordance with IEC 664   |
| <b>Enclosure Material</b>      | ABS/Polycarbonate  |
| <b>Approvals</b>               | General Requirements: ANSI/ISA 82.02.01;<br>Hazardous Location: CSA C22.2 No. 213,<br>E79-15-95, ANSI/ISA 12.12.01<br>Class I Div 2, Groups C & D<br>(DTFXL3 & DTFXL4 models only) |
| <b>4-20 mA Output</b>          | 12-bit, sourcing, DC ground referenced   |
| <b>Pulse Output</b>            | Turbine Frequency Output/Pulse Output—<br>Switch Selectable, non-ground referenced AC/<br>Ground referenced square wave, 0-1,000 Hz,<br>100mVpp minimum/5VDC.                      |

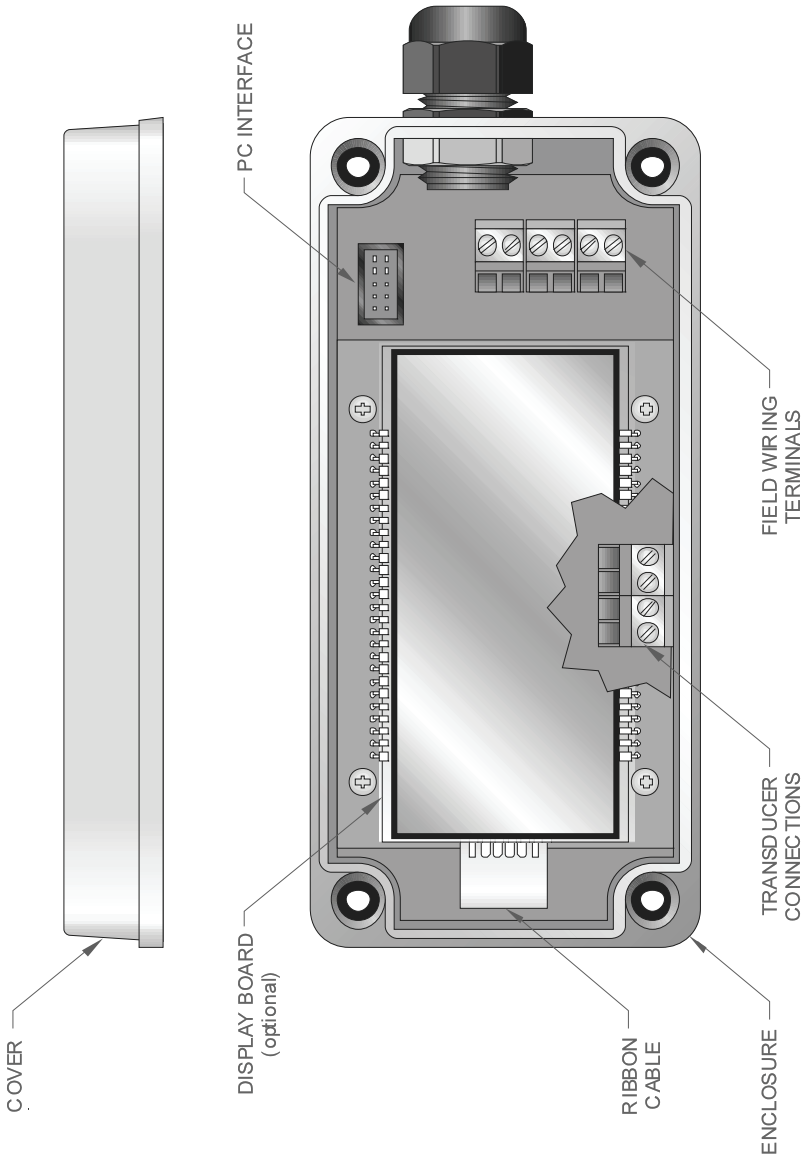
## SYMBOL EXPLANATIONS



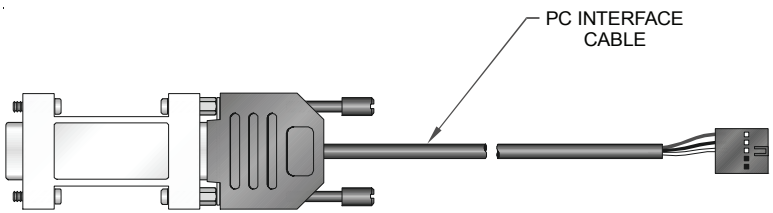
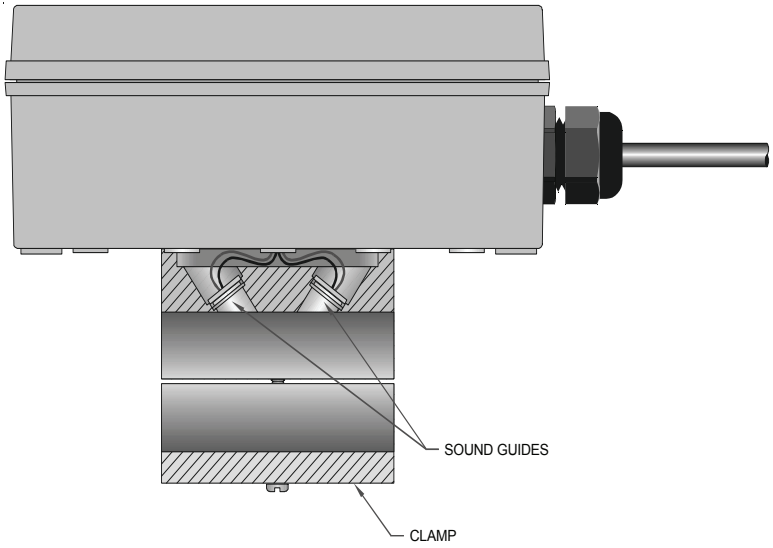
Caution—Refer to accompanying documents

# FLOW METER COMPONENTS AND TERMINOLOGY

The pictures on the following two pages reference key components and their respective terminology of the TFXL flow meter. These terms are utilized throughout this manual.



TERMINOLOGY



# FLOW METER INSTALLATION



**IMPORTANT NOTE:**

Not following instructions properly may impair safety of equipment and/or personnel.



**IMPORTANT NOTE:**

Must be operated by a power supply suitable for the location.



**IMPORTANT NOTE:**

Do not connect or disconnect either power or outputs unless the area is known to be non-hazardous.



**IMPORTANT NOTE:**

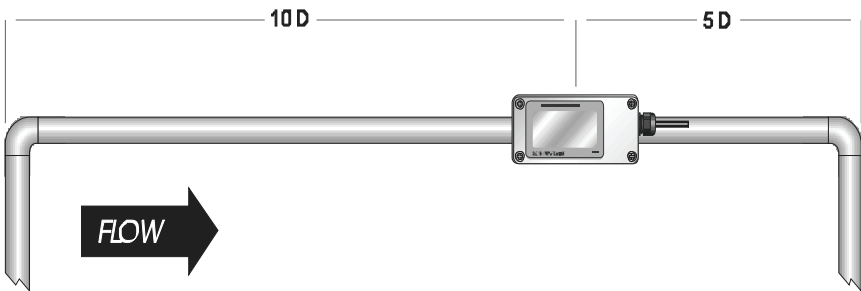
Do not connect the interface cable between a TFXL and a personal computer unless the area is known to be non-hazardous.

## A. FLOW METER LOCATION

The first step in the installation process is the selection of an optimum location for the flow measurement to be made. For this to be done effectively, a basic knowledge of the piping system and its plumbing is required.

An optimum location would be defined as a piping system that is completely full of liquid when measurements are being taken and has lengths of straight pipe such as those described in **Figure 4**. The optimum straight pipe diameter recommendations apply to pipes in both horizontal and vertical orientation.

**Note:** If adequate straight plumbing cannot be provided the TFXL will operate repeatably, but will most likely not achieve ideal accuracy.

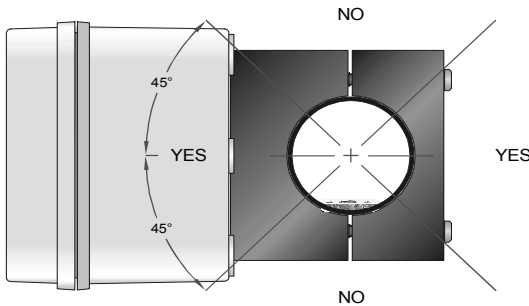


### FLOW METER MOUNTING

**Figure 4—Straight Pipe Recommendations**

## B. MOUNTING ORIENTATION ON THE PIPE

If the flow meter is applied to horizontal pipe, choose a mounting position within approximately 45-degrees of 3 o'clock or 9 o'clock on the pipe, assuming 12 o'clock to be to top of the pipe. These positions provide optimum acoustic penetration into the moving liquid. As illustrated in **Figure 5**, placement at the top or bottom of the pipe can result in poor sound penetration due to air pockets (on the top of the pipe) or sediment (at the bottom of the pipe).



**Figure 5—  
Mounting  
Orientation on  
Horizontal Pipes**

**FLOW METER MOUNTING ORIENTATION**

It is best to plumb and orient the piping system so that it will be completely full of liquid at all times—whether the liquid is flowing or not. Typically, by slightly sloping the pipe in the upward direction or orienting the check valve judiciously within the piping system this can be accomplished.

If the flow meter is applied to vertical pipe with flow moving in an upward direction, radial orientation does not matter.

### C. PIPE PREPARATION

Before the transducer face can be coupled to a pipe surface, an area slightly larger than the flat surface of the transducer must be cleaned to bare metal on the pipe. Remove all scale rust and paint. Thoroughly dry and clean the mounting surface.

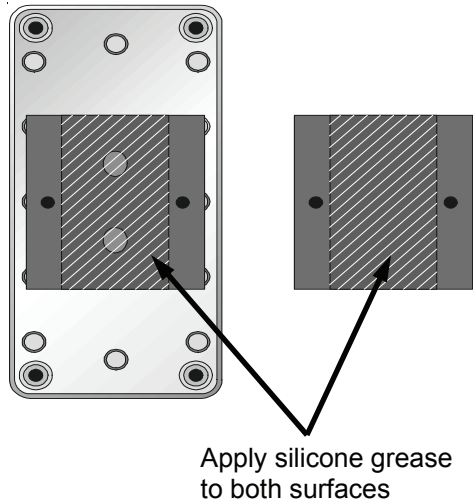
**Note:** For plastic pipes, such as PVC or PVDF, pipe preparation is typically not required.

### D. APPLYING ACCOUSTIC COUPLANT

To assure an acoustically conductive path between the transducer face and the prepared pipe surface, a coupling compound is employed. Enclosed with the TFXL flow meter is a tube of silicone based grease. This grease is adequate for the majority of installations. If an alternate grease is utilized, the grease must be specified not to flow at the temperature of the pipe surface or the ambient conditions.

Apply an even layer of grease, approximately 1/16" [1.5 mm] thick to the entire inside surface of the transducer. See **Figure 6**.

**Figure 6—  
Applying  
Acoustic Couplant**



## E. MOUNTING THE FLOW METER

Place the flow meter on the prepared area of the pipe, observing the flow direction arrow on the side of the flow meter enclosure. Place the flow meter clamp on the backside of the pipe and secure with the two enclosed screws. Tighten only enough to hold the flow meter in place and to squeeze some of the acoustic couplant from the mounting faces. Over tightening may strip the threads and is unnecessary for flow meter operation.

**IMPORTANT NOTE:** Do not rotate the TFXL flow meter on the pipe once the screws have been tightened, as the acoustic grease may be disturbed. If the grease layer between the sound guides and the pipe obtains an air pocket, the flow meter signal strength and, hence, operation may be compromised.

If upon power up the flow meter indicates ERROR 0010 and the pipe is full of liquid, reapplication of the acoustic grease will be necessary.

## F. FIELD WIRING—GENERAL

The TFXL is equipped with a single conduit hole located in the flow meter enclosure that should be suitable for most installations. A sealed cord grip or conduit connection should be utilized to retain the NEMA 3 integrity of the flow meter enclosure. Failure to do so will void the manufacturers warranty and can lead to product failure.

For hazardous area installation, see drawing at back of this manual (D091-1054-001). For non-hazardous location installations, flow meter power and output signals can be carried by a single cable with multiple conductors. Select a 20-24 AWG shielded cable with an external jacket suitable for the installation environment and either 2, 4, or 6 conductors—dependent on the electronic output requirements.

Wiring methods and practices are to be made in accordance with the NEC—National Electric Code and/or other local ordinances that may be in effect. Consult the local electrical inspector for information regarding wiring regulations.

When making connections to the field wiring terminals inside of the flow meter, strip back the wire insulation approximately 0.25

inches [6 mm]. Stripping back too little may cause the terminals to clamp on the insulation and not make good contact. Stripping back too much insulation may lead to a situation where the wires could short together between adjacent terminals. Wires should be secured in the Field Wiring Terminals using a screw torque of between 0.5 and 0.6 Nm.

## G. FIELD WIRING—POWER



### IMPORTANT NOTE:

Must be operated by a power supply suitable for the location.

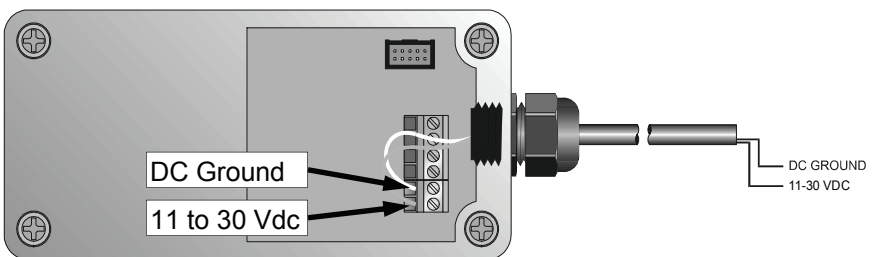


### IMPORTANT NOTE:

Do not connect or disconnect either power or outputs unless the area is known to be non-hazardous.

Power for the TFXL flow meter is obtained from a direct current DC power source. The power source should be capable of supplying between 11 and 30 Vdc at a minimum of 0.25 Amps or 250 milliamps. With the power from the DC power source disabled or disconnected, connect the positive supply wire and ground to the appropriate field wiring terminals in the flow meter. See **Figure 7**. A wiring diagram decal is located on the inner cover of the flow meter enclosure.

If the flow meter is only to be utilized as a flow rate indicator or totalizer, no further wiring will be required. Skip to step J.

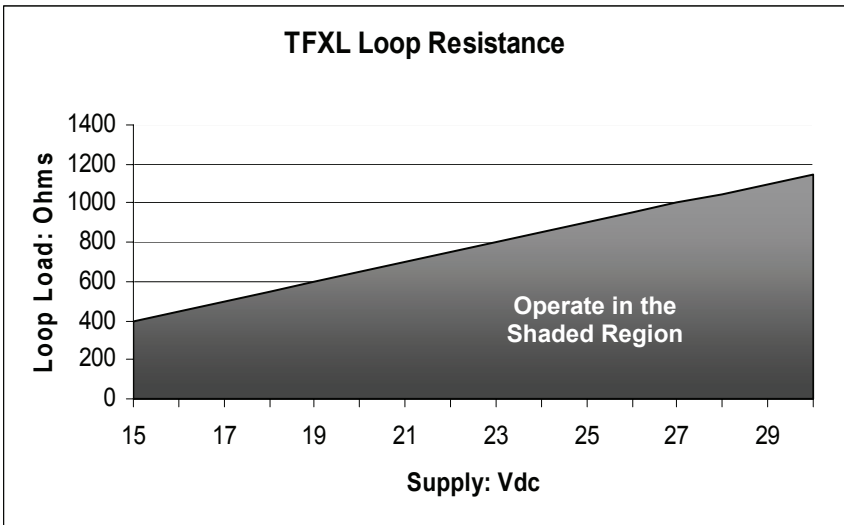


**Figure 7**  
**DC Power Connection**

## H. CONNECTING THE 4-20 mA OUTPUT

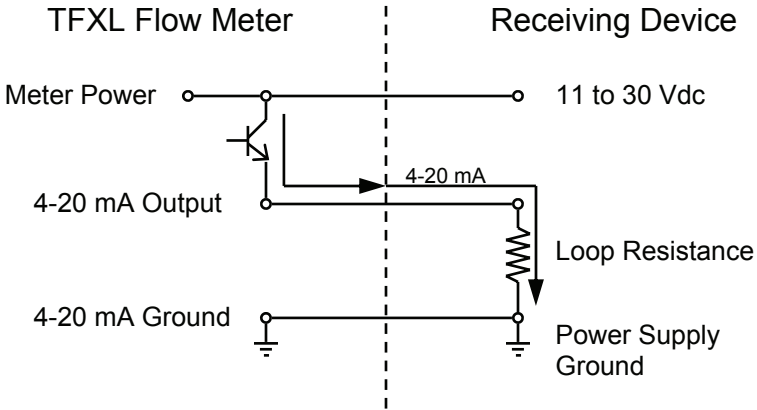
The TFXL is equipped with a ground-referenced 4-20 mA output—the output shares a common ground with the power supply. The output transmits a continuous current output that is proportional to liquid flow rate. The output was scaled at the Dynasonics factory and the scaling information is recorded on the label located on the side of the TFXL enclosure. To ensure that the instrument or data acquisition system that is receiving the 4-20 mA signal responds properly, it must be spanned identically to the TFXL.

The 4-20 mA output is designed to source current across a loop resistance that is typically located within a data acquisition system or other receiving instrument. The maximum resistance that the TFXL can accommodate is directly related to the DC power source that is powering the flow meter and the 4-20 mA loop. **Chart 1** illustrates the range of load resistance that can be used with a given power supply voltage. Ensure that the loop load resistance is within the shaded region of the graph, or non-linearity and transmitting errors will occur.



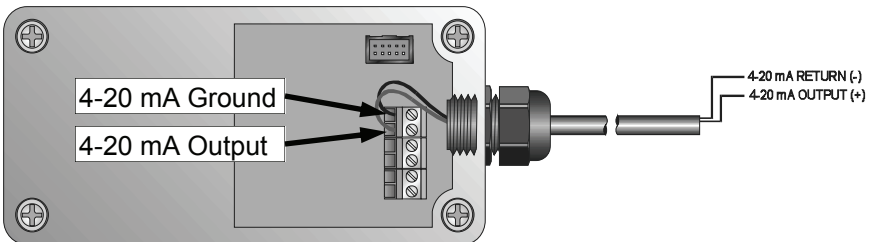
**Chart 1**  
**4-20 mA Loop Load**

The 4-20 mA output is polarized and since the output shares the DC common with the power supply, reversing the connections can cause a short circuit in the DC power circuit. **Figure 8** shows a block diagram of how the 4-20 mA interfaces with the receiving device.



**Figure 8**  
4-20 mA Block  
Diagram

Connect the wires to the appropriate Field Wiring Terminals within the TFXL enclosure. See **Figure 9**.



**Figure 9**  
4-20 mA Connections

## I. CONNECTING THE PULSE OUTPUT

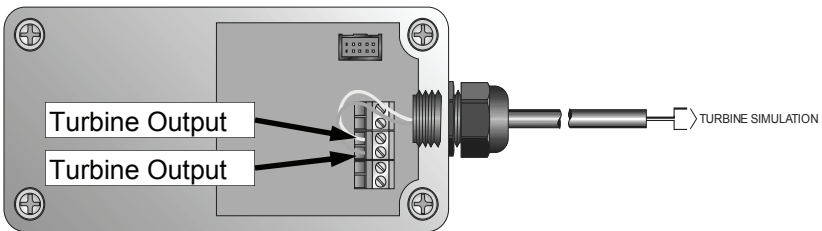
The TFXL is equipped with a circuit that outputs a pulse waveform that varies proportionally with flow rate. The quantity of pulses per unit volume of liquid is described by the K-factor that is recorded on the side of the flow meter enclosure. To ensure that accurate readings are being recorded by the receiving instrument, the TFXL and the receiving instrument must have identical K-factor values programmed into them.

Two pulse output options are available with the TFXL:

- ◆ Turbine meter simulation—This option is utilized when a receiving instrument is capable of interfacing directly with a turbine flow meter’s magnetic pickup. The output is a relatively low voltage AC signal that is not ground referenced. The minimum AC amplitude is approximately 500 mV peak-to-peak. The TFXL is configured for turbine simulation if the third character after the first dash number in the model number is a “1”. Dip switch SW1 must be in the off or open position.
- ◆ TTL pulse frequency—This option is utilized when a receiving instrument requires that the pulse voltage level be either of a higher potential and/or referenced to DC ground. The output is a square-wave with a peak-to-peak voltage swing of 5 volts. The TFXL is configured for TTL pulse frequency if the third character after the first dash number in the model number is a “2”. Dip switch SW1 must be in the on or closed position.

## Turbine Meter Simulation Output Connection

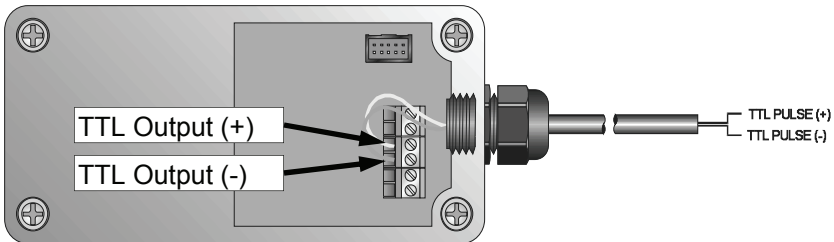
Connection of the turbine meter simulation output is simply a matter of connecting the two Field Wiring Terminals to the turbine meter input terminals on the receiving instrument and verifying that the K-factor listed on the side of the TFXL enclosure is programmed into the receiving instrument. This output is not referenced to DC ground and is not polarized, so wiring polarity is not important. See **Figure 10**.



**Figure 10**  
**Turbine Meter**  
**Simulation Connections**

## TTL Pulse Frequency Connection

Connection of the TTL pulse frequency output is a matter of connecting the two Field Wiring Terminals to the frequency input terminals on the receiving instrument and verifying that the K-factor listed on the side of the TFXL enclosure is programmed into the receiving instrument. This output is referenced to DC ground and is polarized. Connect the TTL Pulse plus (+) field terminal in the flow meter to the frequency input on the receiving instrument. Connect the TTL Pulse negative (-) field terminal to the frequency input negative or DC common connection in the receiving instrument. See **Figure 11**.



**Figure 11**  
**TTL Pulse Output**  
**Connections**

## J. APPLYING POWER TO THE TFXL

The TFXL flow meter requires a full pipe of liquid before a successful startup can be completed. Do not attempt to make adjustments or change configurations until a full pipe is verified.

1. Verify that all wiring is properly connected and routed as described in Steps A through I of this manual.
2. Verify that the flow sensor is properly mounted and that the acoustic grease is intact between the transducer faces and the pipe.
3. Apply power. The display of the TFXL2 (with a display) will display a display test where all segments will illuminate in

succession and then the software version will be displayed. The meter will then enter RUN Mode. If the flow meter is a TFXL1 (without a display) verify that one of the red LEDs on the main printed circuit board is illuminated continuously and that the other one begins to blink.

4. Upon entering RUN Mode, the TFXL2 will provide one of the following responses:

- ◆ The display may indicate ERROR 0010, which indicates low signal strength. Low signal strength is caused by one of the following:

- ⇒ an empty pipe (gas locked)

- ⇒ gas content in the liquid that exceeds 50%

- ⇒ inadequate acoustic grease between the flow meter transducer and the pipe

- ⇒ a broken connection between a transducer and the main circuit board—check wire terminations under the display.

- ◆ The display may indicate a flow rate.

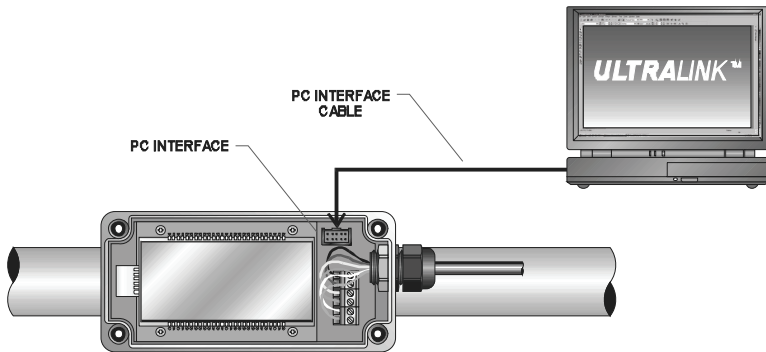
- ⇒ If 0.000 is indicated, it means that the meter is operating properly, but that the liquid is not moving.

- ⇒ A negative value would indicate that flow is moving backwards—against the flow direction arrow. A standard TFXL will not output flow signals under this condition.

- ⇒ The flow meter indicates flow rate. This verifies that signal strength is adequate and that the flow is moving in the direction that the flow arrow signifies.

5. TFXL1 Responses—The TFXL1 is not equipped with a display, so troubleshooting requires the use of a computer and a PC interface cable. See pages 22-28.

# ULTRALINK COMPUTER SOFTWARE



The UltraLink utility has been designed to provide the TFXL user with a powerful and convenient way to configure, troubleshoot and calibrate TFXL flow meters. Several operating features can be setup or revised from factory set values using the UltraLink utility.

## **Minimum PC Requirements**

Computer type - PC, operating system: Windows 95/98/2000/ME/XP, an RS232 serial communications port, hard disk and CD-ROM drive.

## **Installation**

1. Place the enclosed diskette or CD-ROM into the diskette or PC CD-ROM drive.
2. If the CD drive is setup to automatically launch setup files when it is closed, the installation Unwise® Installation Wizard window will appear and prompt the installer. If the program is initialized from a diskette or if the CD-ROM drive is not setup for automatic launch, press the START/RUN button, select ULSetup.exe from the diskette or the CD-ROM drive and click OK.
3. **UISetup** will automatically extract and install on the hard disk and place two short-cut icons on the desktop.
4. Most PCs will require a restart after a successful installation.

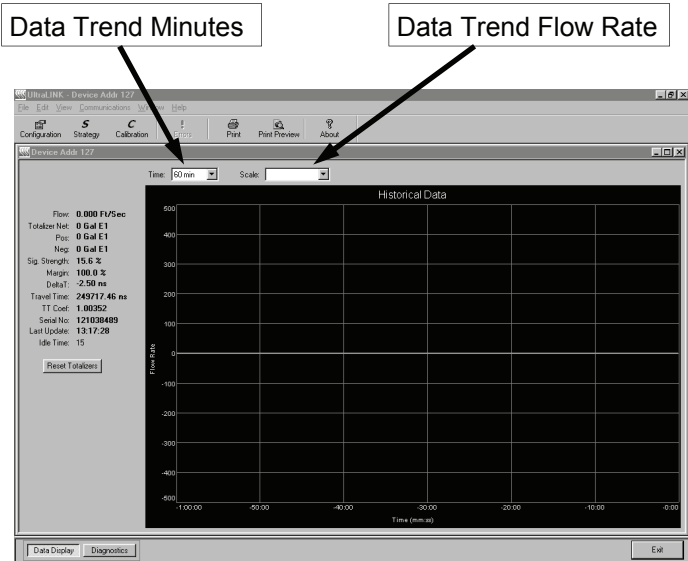
# UltraLink Initialization

## IMPORTANT NOTE:



Do not connect the interface cable between a TFXL and a personal computer unless the area is known to be non-hazardous.

1. Connect the PC to the TFXL flowmeter by connecting the PC interface cable between a COM port on the PC and the PC Interface connection within the TFXL flow meter—See Page 8 for location of the connector.
2. Double-click on the **UltraLink** icon. If it is the first time that UltraLink has been run on the computer, UltraLink will test Communications Port 1 for connection with the TFXL meter. If Comm port 1 is already in use by another application, UltraLink will prompt for another Comm port number. Once UltraLink has established communications, it will default to that setup upon program launch.



**Figure 12**  
**UltraLink Data Screen**

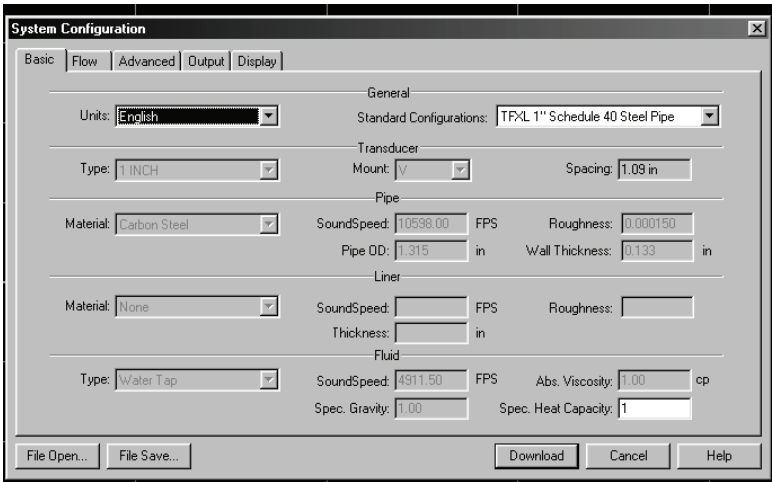
3. The opening screen, shown in **Figure 12**, is called the Data Screen. It contains a large data trend chart that can be adjusted for both the X(time) and Y(flow rate) axis. This screen also contains real-time information regarding flow rate, totalizer accumulations, system signal strength and diagnostic data. The indicator in the lower right-hand corner will indicate communications status. If a red **ERROR** appears, click on the Communications button on the top bar. Click on Initialize. Choose the appropriate COM port and RS232. Proper communications are established when a green **OK** is indicated in lower right-hand corner of the PC display.

**NOTE:** Power on unit may need to be cycled in order to establish communication.

4. Click on the button labeled **Configuration** for updating flow range, liquid, pipe and I/O operating information. The first screen that appears after clicking the **Configuration** button is the **BASIC** tab. See **Figure 13**.

5. **BASIC TAB**—See **Figure 13**

- **General Units** allows selection of either English (U.S.) or Metric units of measure. If measurements of the pipe are to be entered in inches, select English. If pipe measurements



**Figure 13 — Basic Tab**

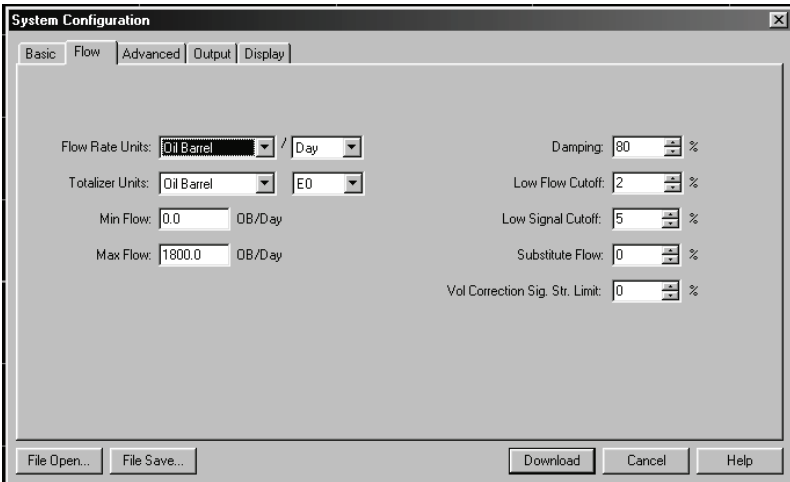
are to be entered in millimeters, select Metric. It is recommended that if the General Units are altered from those at instrument startup, that the Download button be pressed on the lower right-hand portion of the screen and that the TFXL have its power cycled.

- **Standard Configurations** contains the most popular applications for the TFXL. The TFXL has been constructed and configured at the Dynasonics factory for a specific pipe size. If the Standard Configuration does not match the pipe schedule or material, select the proper configuration from the drop down list. If the pipe schedule is not listed or if the liquid is not water, select **Other** on the drop down list and fill in the proper information on the setup screen.

**TFXL flow meters are constructed and configured at the Dynasonics factory for a single pipe size. Altering pipe material and schedule is possible, but do not change pipe size or the meter may not operate or may operate with a large error.**

#### 6. **FLOW** Tab—See **Figure 14**

- **Flow Rate Units** are selected from the pull down lists. Select an appropriate rate unit and rate time-base from the two lists.
- **Totalizer Units** are selected from pull down lists. Select an appropriate totalizer unit and totalizer exponent. The totalizer exponents are in Scientific Notation and permit the eight digit totalizer to accumulate very large values before the totalizer “rolls over” and starts again at zero. **Table 1** illustrates the Scientific Notation values and their respective decimal equivalents.
- **MIN Flow** is used by the TFXL to establish filter settings in its operating system. Enter a flow rate that is the minimum flow rate anticipated within the system. For uni-directional systems, this value is typically zero. For bi-directional systems this value is set to a negative number that is equal to the maximum negative flow rate that is anticipated within the system.



**Figure 14  
Flow Tab**

**TABLE 1—Totalizer Exponent Values**

| <b>Exponent</b> | <b>Display Multiplier</b> |
|-----------------|---------------------------|
| <b>E-1</b>      | X 1 (No multiplier)       |
| <b>E0</b>       | X 1 (No multiplier)       |
| <b>E1</b>       | X10                       |
| <b>E2</b>       | X100                      |
| <b>E3</b>       | X1,000                    |
| <b>E4</b>       | X10,000                   |
| <b>E5</b>       | X100,000                  |
| <b>E6</b>       | X1,000,000                |

- **MAX Flow** is used by the TFXL to establish filter settings in its operating system. Enter a flow rate that is the maximum, positive flow rate anticipated within the system.
- The **Damping** value is increased to intensify stability of the flow rate readings. Damping values are decreased to allow the flow meter to react faster to changing flow rates.
- **Low Flow Cutoff** is entered as a percentage of MAX Flow and influences how the flow meter will act at flows very near zero. Generally, an entry of 1% provides for a stable zero indication, while providing a 100:1 turndown ratio for measurements.
- **Low Signal Cutoff** is a relative value that should be entered after a successful flow meter startup. For an initial value, enter 5% [Signal Strength indications below 3% are considered to be below the noise ceiling and should not be indicative of a successful flow meter startup.] The entry has three purposes: provides an error indication—Low Signal Strength [Error 0010 on the TFXL display] when liquid conditions in the pipe have changed to the point where flow measurements may not be possible, warns if the pipe's liquid level has fallen below the level of the transducers, and signals that something with the flow meter installation or configuration may have changed. Examples would include such things as the couplant used to mount the transducer has become compromised, a cable has become disconnected or a pipe size setting has been altered.
- **Substitute Flow** is used to provide an indication and output that signifies that an error exists with the flow meter or its setup. It is set as a percentage between MIN Flow and MAX Flow. In a uni-directional system this value is typically set to zero, to indicate zero flow while in an error condition. In a bi-directional system, the percentage can be set such that zero is displayed in a error condition. To calculate out where to set the Substitute Flow value in a bi-directional system perform the following operation:

SUBSTITUTE FLOW =

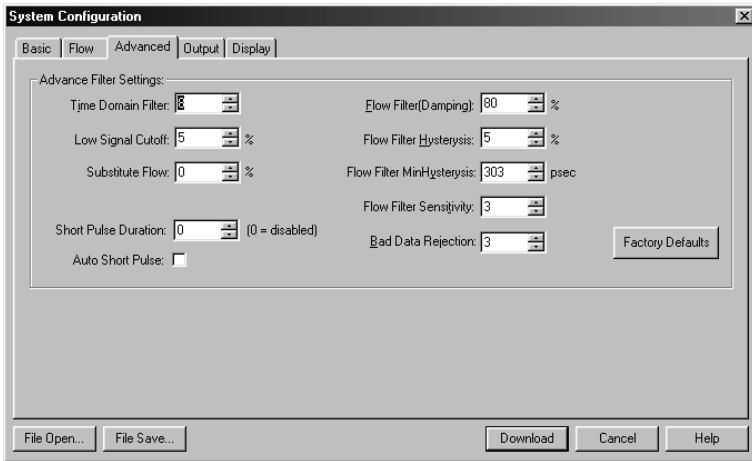
$$100 - \frac{100 \times \text{MAX Flow}}{\text{MAX Flow} - \text{MIN Flow}}$$

- **Vol. Correction Sig. Str. Limit** is a feature used to provide volumetric compensation for gas bubbles that can be present in liquid systems. The TFXL measures the velocity of the liquid in the pipe and converts that velocity to volume by multiplying the velocity by the cross-sectional area of the pipe. If there are gas bubbles within the liquid, the gas is displacing some of the liquid and errors can occur. When Vol. Correction Sig. Str. Limit is set to zero, the compensation function is not operational. To use the feature, enter the maximum Signal Strength observed on the flow meter after installation. The maximum signal strength should occur with the pipe completely full of liquid and the flow stopped. Signal Strength can be observed on the UltraLink Data Screen. See **Figure 12**.
- Entry of data in the **Basic** and **Flow** tabs are all that is required to provide flow measurement functions to the flow meter. If the user is not going to utilize input/output functions, click on the **Download** button to transfer the configuration to the TFXL instrument.

## 7. **ADVANCED TAB**—See **Figure 15**

The Advanced TAB contains several filter settings for the TFXL flow meter. These filters can be adjusted to match response times and data “smoothing” performance to a particular application. The factory settings are suitable for most installations.

- **Time Domain Filter** adjusts the number of raw data sets (the wave forms viewed on the UltraLink Diagnostics Screen) that are averaged together. Increasing this value will provide greater damping of the data and slow the response time of the flow meter. This filter is not adaptive—it is operational to the value set at all times.
- **Low Signal Cutoff** is a duplicate entry from Page 27. Adjusting this value adjusts the value on the Flow TAB.
- **Substitute Flow** is a duplicate entry from Page 27. Adjusting this value adjusts the value on the Flow TAB.
- **Short Pulse Duration** is a function used on pipes larger than 8 inches [200 mm]. Set this value to zero to disable the function. Do not select the **Auto Short Pulse** box.



**Figure 15**  
**Advanced Tab**

- **Flow Filter Damping** establishes a maximum adaptive filter value. Under stable flow conditions (flow that varies less than the **Flow Filter Hysteresis** entry) this adaptive filter will increase the number of successive flow readings that are averaged together up to this maximum value. If flow changes outside of the **Flow Filter Hysteresis** window, the Flow Filter adapts by decreasing and allows the meter to react faster. Increasing this value tends to provide smoother steady-state flow readings and outputs.
- Flow Filter Hysteresis creates a window around the average flow measurement reading whereby if the flow varies within that window, greater **Flow Filter Damping** will occur. The filter also establishes a flow rate window where measurements outside of the window are captured by the **Bad Data Rejection Filter**. The value is entered as a percentage of actual flow rate.

*Example:*

If the average flow rate is 100 GPM and the Flow Filter Hysteresis is set to 5%, a filter window of 95-105 GPM is established. Successive flow measurements that are measured within that window are recorded and averaged in accordance with the **Flow Filter Damping** setting.

Flow readings outside of the window are held up in accordance with the **Bad Data Rejection Filter**.

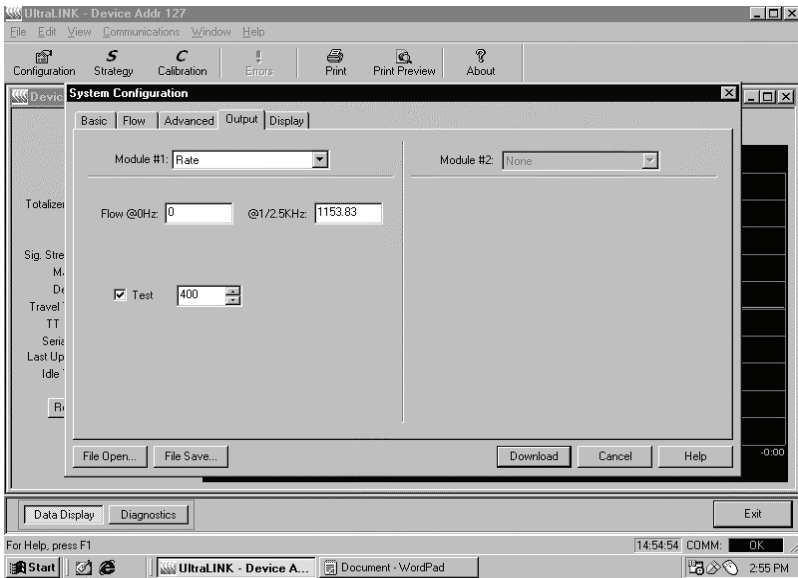
- **Flow Filter MinHysteresis** sets a minimum hysteresis window that is invoked at low flow rates, where the “of rate” **Flow Filter Hysteresis** is very small and ineffective. This entry is entered in pico-seconds and is differential time. This value is factory set and should not be altered without consulting the Dynasonics technical services department.
- **Flow Filter Sensitivity** allows configuration of how fast the **Flow Filter Damping** will adapt in the positive direction. Increasing this value allows greater damping to occur faster than lower values. Adaptation in the negative direction is not user adjustable.
- Bad Data Rejection is a value related to the number of successive readings that must be measured outside of the Flow Filter Hysteresis and Flow Filter MinHysteresis windows before the flow meter will use that flow value. Larger values are entered into the Bad Data Rejection when measuring liquids that contain gas bubbles, as the gas bubbles tend to disturb the ultrasonic signals and cause more extraneous flow readings to occur. Larger Bad Data Rejection values tend to make the flow meter more sluggish to rapid changes in actual flow rate.

## 8. Output TAB—See **Figure 16**

The entries made in the Output TAB establish range factors for the 4-20 mA and frequency outputs on the meter. The 4-20mA is calibrated at the Dynasonics factory and cannot be altered in the field. However, the range of the output can be altered.

The unit has been factory calibrated to output 1KHz at the maximum flow rate. To change the frequency output at full scale, the value for the “Flow @1KHz” must be altered. This may be required when installing the meter to replace a turbine style flow meter. This example shows how to change the frequency output to match that of a turbine style flow meter.

$$\frac{\text{Max flow rate}}{\text{Required frequency @max flow}} = \frac{\text{Flow @1KHz}}{1000\text{Hz}}$$



**Figure 16  
Output Tab**

- 1) To determine the frequency out of a turbine meter at maximum flow, convert the maximum flow rate to gallons/second, then multiply by the nominal K-factor (pulses/gallon).
- 2) Calculate the flow rate that corresponds to 1000Hz. Multiply the maximum flow rate times 1000Hz, then divide by the required frequency at maximum flow.
- 3) Enter this value in the “Flow @1KHz” field.

*Example:*

Maximum Flow Rate = 400 GPM

Desired K-factor = 52 pulses/gallon

400 gallons/minute = 6.67 gallons/second

6.67 gallons/second x 52 pulses/gallons = 346.67Hz

Therefore:

$(400 \text{ GPM} \times 1000\text{Hz}) / 346.67\text{Hz} = 1153.83 \text{ GPM}$

Enter 1153.83 into the “Flow @1KHz” field.

To adjust the range of the 4-20mA output, simply enter the flow rate that corresponds to 4mA output in the “Flow @0Hz” field. Enter the flow rate that corresponds to 20mA output in the “Flow @ 1KHz” field.

## **9. Display TAB—See Figure 17**

The Display TAB permits configuration of the flow meter display.

### **Display**

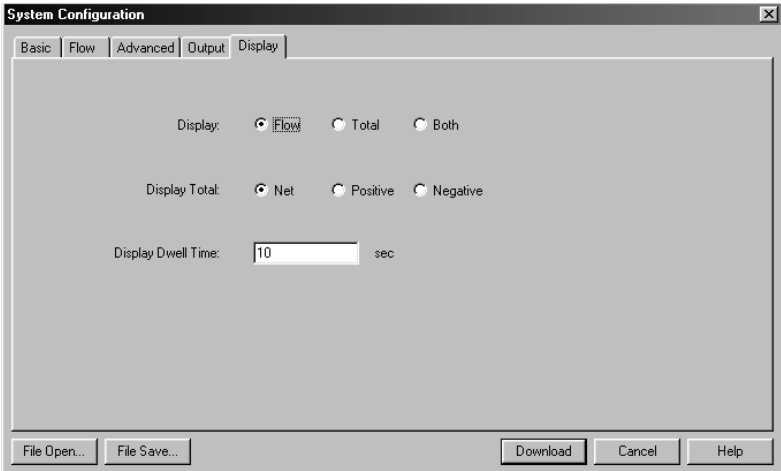
- Select Flow to display flow rate only on the display.
- Select Total to display the flow accumulator only on the display.
- Select Both to periodically toggle between rate and accumulated flow displays.

### **Display Total**

- Select Net to display the accumulated difference between the positive and negative totalizers. This feature will subtract backflow (drain back) from the totalizer value.
- Select Positive to display only flows moving in the forward direction.
- Select Negative to display only flows moving in the backwards direction.

## Display Dwell Time

- Enter a value between 1 and 10 seconds to establish how long the flow meter will display flow rate, then accumulated total, then rate and so on.

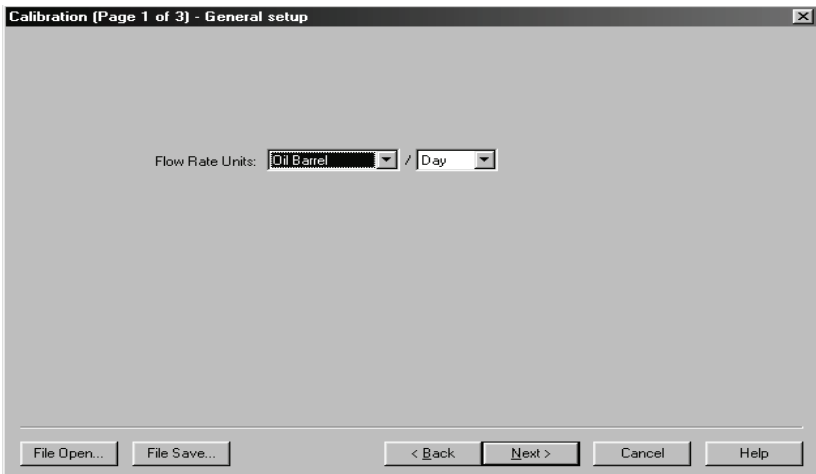


**Figure 17**  
**Display Tab**

## Setting Zero and Calibration

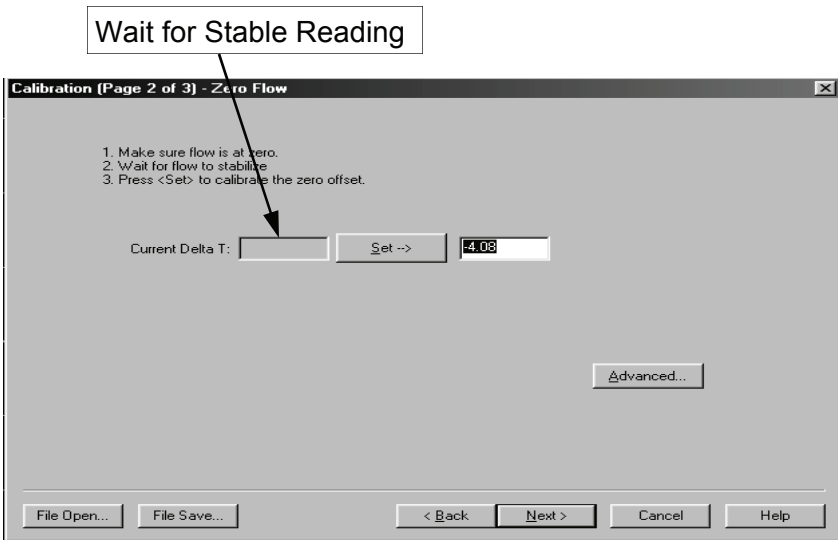
UltraLink contains a powerful multi-point calibration routine that can be used to calibrate the TFXL flow meter to a primary measuring standard in a particular installation. To initialize the three step calibration routine, press the Calibration button located on the top of the **UltraLink Data Screen**. The display shown in **Figure 18** will appear. The first step in the calibration process is the selection of the engineering units that the calibration will be performed with. Select the units and press the Next button at the bottom of the window.

NOTE: Changes here will invalidate the current calibration.

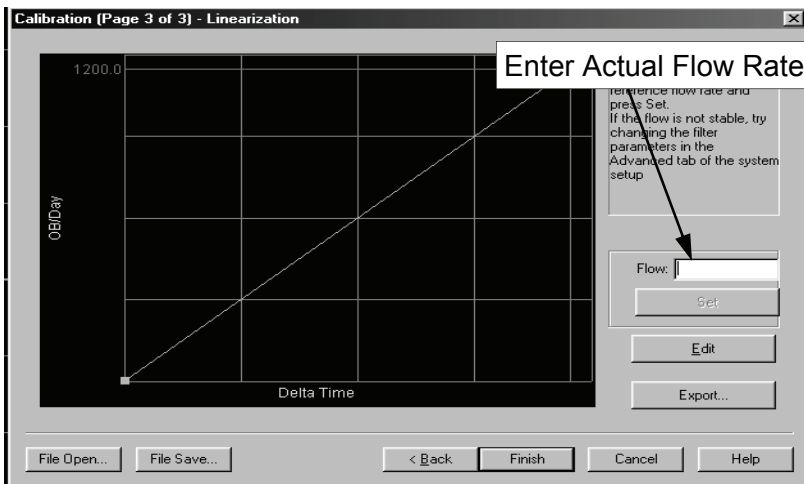


**Figure 18**  
**Calibration Units**

The second screen, **Figure 19**, establishes a baseline zero flow rate measurement for the instrument. To zero the flow meter, establish zero flow in the pipe (turn off all pumps and close a dead-heading valve). Wait until the delta-time interval shown in **Figure 19** is stable (and typically very close to zero). Press the **Set** button. Press the **Next** button when complete, then press the **Finish** button on the Calibration Screen. If the **Set** button was pressed, do not proceed with Flow Rate Calibration before pressing the **Finish** button to save the Zero setting.



**Figure 19**  
**Setting Zero Flow**



**Figure 20**  
**Flow Rate Calibration**

The screen shown in **Figure 20** allows multiple actual flow rates to be run past the meter and the values recorded by the TFXL. To calibrate a point, establish a stable, known flow rate (verified by a real-time primary flow instrument), enter the actual flow rate in the **Figure 20** window and press the **Set** button. Repeat for as many points as desired. Note: If only one point is to be used, it is preferred that a flow rate as high as anticipated in normal operation is used as the calibration point. If an erroneous data point is collected, the point can be removed by pressing the **Edit** button, selecting the bad point and selecting Remove.



**WARNING:**

Do not enter a zero point on this screen. A zero will cause the TFXL to read no flow.

Press the **Finish** button when all points have been gathered.

## **Saving Meter Configuration on a PC**

The complete configuration of the flow meter can be saved from the **Configuration** screen. Select **Save** and name the file. This file may be transferred to other flow meters or may be recalled should the same pipe be surveyed again or multiple meters programmed with the same information.

## **Printing Out a Flow Meter Configuration and Calibration Report**

Select **File** from the upper task bar and **Print** to print out a calibration/configuration information sheet for the flow meter installation.

## **Maintenance**

No periodic maintenance is required for this product.

# TROUBLESHOOTING GUIDE

|   |  |
|---|--|
| <b>Unit does not turn “ON” when power is applied</b>              | <ul style="list-style-type: none"><li>• Verify that voltage in the range of 11-30 Vdc is present at the field terminals</li><li>• If the voltage is present and neither LED on the main printed circuit board is illuminated, return the flow meter to the Dynasonics factory for evaluation.</li></ul>  |
| <b>Unit reads zero flow when flow is actually running</b>         | <ul style="list-style-type: none"><li>• Verify that the Maximum Flow Rate value is not set to a very high value and causing the Flow Cutoff percent entry to drive the readings to zero. Decrease Max Flow setting or decrease Flow Cutoff percentage.</li><li>• Verify that a zero was not entered on page 3 of the calibration screen.</li></ul>   |
| <b>ERROR 0010 is Displayed on the Screen</b>                      | <ul style="list-style-type: none"><li>• The flow meter is not mounted onto the pipe using an acoustic couplant.</li><li>• The acoustic couplant is not uniform between the flow meter transducer and the pipe.</li><li>• The liquid contains more than 50% suspended gas bubbles.</li><li>• The pipe is full of gas—gas locked.</li></ul>  |
| <b>Flow Meter Reads Negative Flow Readings</b>                    | <ul style="list-style-type: none"><li>• Flow is running backwards when compared to the FLOW DIRECTION arrow located on the side of the flow meter enclosure.</li></ul>   |
| <b>Flow Meter is Reading Flow, But Output Is Not Transmitting</b> | <ul style="list-style-type: none"><li>• Verify that one of the LEDs on the main printed circuit board is flashing—if not, return the flow meter to the Dynasonics factory.</li><li>• Verify connections and polarity of wiring.</li><li>• Test output with a milliamp meter, oscilloscope or other test instrument</li><li>• Verify that the output is configured for RATE (Figure 16)</li></ul> |

## STATEMENT OF WARRANTY

Dynasonics Division, Racine Federated, Inc. (hereinafter "the Company") warrants its products under normal use and service to be free of defects in material and workmanship for a period of twelve (12) months from date of shipment (the "Warranty Period").

This Warranty does not apply to defects caused by acts of God, abuse, misuse, vandalism or improper installation or operation. Further, this Warranty does not apply to products that have been altered or improperly repaired by a party other than the Company or its authorized agents.

To make claim under this Warranty, the Customer must notify the Company in writing within the Warranty Period. The Company may either repair or replace, at its option, any products found to be defective. Return to the Customer of repaired items will be shipped freight prepaid by the Company. Any repaired products shall be warranted for the remainder of the unexpired Warranty Period plus the amount of time the product was under repair, or for a period of 90 days, whichever is longer.

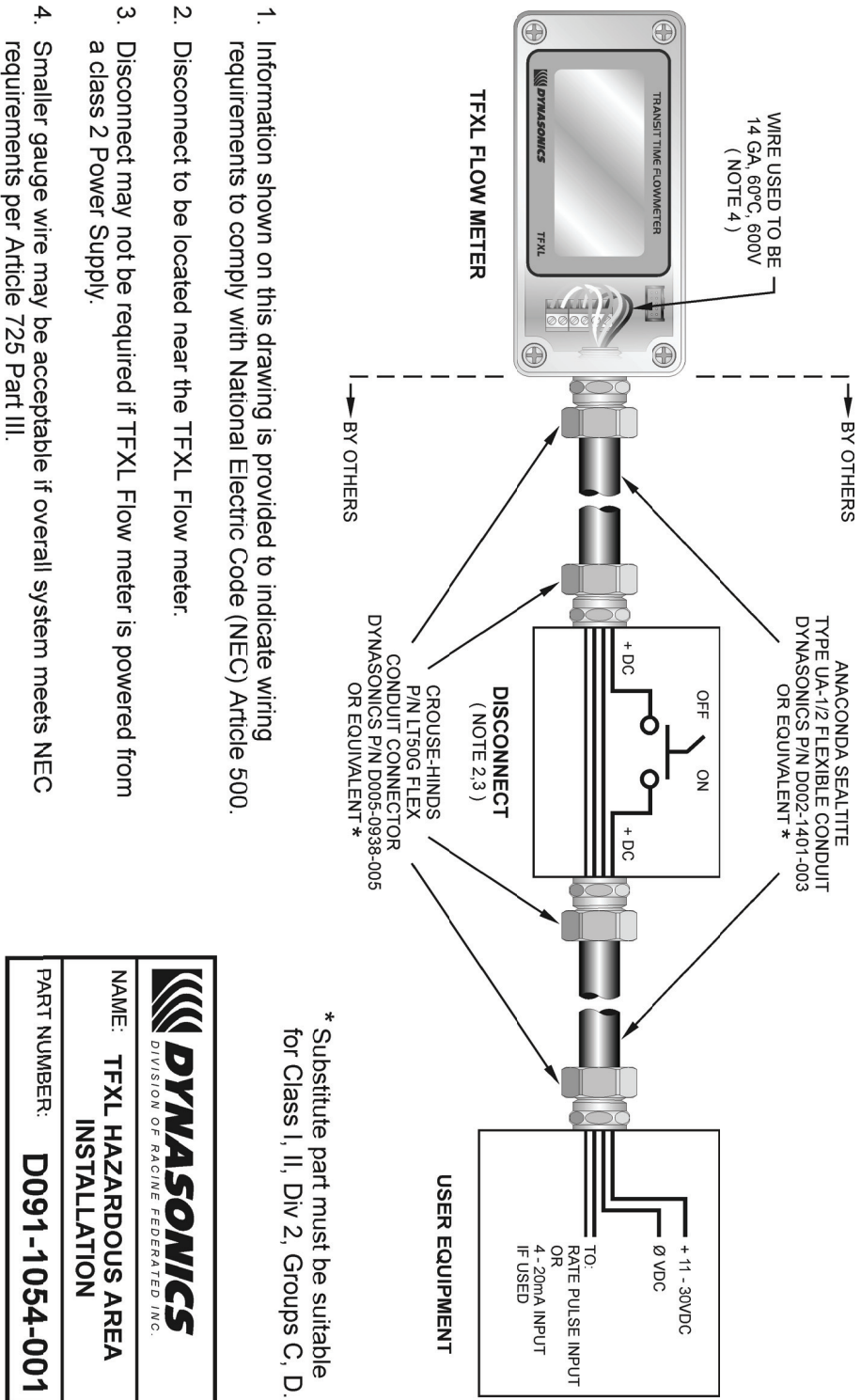
This Warranty is in lieu of all other warranties, express or implied, including, without limitation, any implied warranty of merchantability or fitness for a particular purpose. The sole and exclusive liability of the Company hereunder shall be to repair or replace a defective product or part, or if unable to do so, refund the purchase price of the product at the Company's option.

In all events, the Company shall not be liable for special, indirect, incidental or consequential losses or damages of any kind or nature whatsoever, even if the Company has been advised of the possibility of such loss or damage. No waiver, alteration or modification of this Warranty shall be binding against the Company unless in writing and signed by an authorized executive officer of the Company.

## **SERVICE AND REPAIR**

When returning equipment, it is necessary for you to contact our service department at (800) 535-3569 or (262) 639-6770 to obtain an RGA number for the authority and tracking of your material and its proper inspection and return. All returns of equipment must go to the following address:

**Dynasonics  
Attn: RGA#xxxx  
8635 Washington Avenue  
Racine, WI 53406**



|  |  |
|--|--|
| <br><b>DYNAMSONICS</b><br>DIVISION OF RACINE FEDERATED INC. |  |
| <b>NAME: TFXL HAZARDOUS AREA<br/>INSTALLATION</b>  |  |
| <b>PART NUMBER: D091-1054-001</b>  |  |

# NOTES





8635 WASHINGTON AVENUE  
RACINE, WI 53406

TOLL-FREE IN NORTH AMERICA.:

TEL: (800) 535-3569 FAX: (800) 732-8354

TEL: (262) 639-6770 FAX: (262) 639-2267

URL: [www.dynasonics.com](http://www.dynasonics.com)